

OxyGO[®]



PM 1210-0400 shown

ConservOx[™] OXYGEN CONSERVING REGULATOR

CGA 870 Connection

R_x ONLY



CONTENTS

RECEIVING / INSPECTION.....	1
INTENDED USE.....	1
READ ALL INSTRUCTIONS BEFORE USING.....	2
EXPLANATION OF ABBREVIATIONS.....	2
SAFETY INFORMATION.....	2
WARNINGS AND CAUTIONS.....	3
PRINCIPLES OF OPERATION.....	5
SPECIFICATIONS.....	6
COMPONENT DESCRIPTION.....	7
INSTALLATION.....	8
OPERATING INSTRUCTIONS.....	9
MAINTENANCE / CLEANING.....	11
RETURNS.....	11
DISPOSAL INSTRUCTIONS.....	11
TROUBLESHOOTING.....	12
LIMITED WARRANTY.....	13

RECEIVING / INSPECTION

Remove the OxyGo **ConservOx** *Oxygen Conserving Regulator (Conserver)* from the packaging and inspect for damage. If there is any damage, **DO NOT USE** and contact your Provider.

INTENDED USE

To regulate high pressure cylinders that provide supplemental oxygen to patients who may have difficulty extracting oxygen from the air they breathe. It is for patients who would normally receive the oxygen via a nasal cannula. The device delivers 100% oxygen at flow settings. It is intended to be used as an oxygen saving device that reduces the drying of the airways.

READ ALL INSTRUCTIONS BEFORE USING

This manual instructs the user to install and operate the *OxyGo ConservOx Oxygen Conserving Regulator (Conserver)*. This is provided for your safety and to prevent damage to the Conserver. If you do not understand this manual, DO NOT USE the Conserver and contact your Equipment Provider.

DANGER

This product is not intended as a life-sustaining or life-supporting device.

EXPLANATION OF ABBREVIATIONS

kPa	Kilopascal
psi	Pounds Per Square Inch
l/min	Liters Per Minute
b/min	Breaths Per Minute

SAFETY INFORMATION - WARNINGS AND CAUTIONS

DANGER

Indicates an imminently hazardous situation which, if not avoided, will result in death or serious injury.

WARNING

Indicates a potentially hazardous situation which, if not avoided, could result in death or serious injury.

CAUTION

Indicates a potentially hazardous situation which, if not avoided, may result in minor or moderate injury.

CAUTION

Used without the safety alert symbol indicates a potentially hazardous situation which, if not avoided, may result in property damage.



CONSULT ACCOMPANYING DOCUMENTS



Symbol for "USE NO OIL"



Symbol for "NO SMOKING"



Symbol for "COVERING DEVICE WITH GARMENTS WILL PRODUCE OXYGEN ENRICHED ATMOSPHERE"

WARNING

- You equipment provider is responsible to:
 - ensure the compatibility of the oxygen conserving equipment and all of the parts and accessories used to connect to the patient before use,
 - ensure that the oxygen delivery settings were determined and recorded for the patient individually together with the configuration of the equipment to be used, including accessories, and
 - periodically reassess the setting(s) of the therapy for effectiveness
- Always follow standards for Medical Gas Products, and High Pressure Oxygen Handling. In the United States, ANSI, CGA and G-4 applies.
- Keep cylinder valve closed at all times when cylinder is not in use.
- NO OXYGEN is delivered when the pointer ∇ is aligned with "OFF".

• **CONTRAINDICATION:**

The ConservOx Conserver should not be used for:

- Tracheotomised patient
- Patients who breathe through their mouths or oxygen masks
- Source of oxygen while sleeping
- **DO NOT** use if dirt or contaminants are present on or around cylinder, valve, the Conserver or connecting devices.
- **DO NOT** use oils, greases, organic lubricants or any combustible materials on or near the Conserver. Wash and dry hands properly prior to use.
- **DO NOT** use a humidifier with the Conserver.
- **DO NOT** allow cylinders to tip or fall. Secure gas cylinders so they cannot fall. For optimum safety keep cylinder upright whenever possible.
- **DO NOT** store cylinders near sources of heat or flame.
- Smoking during oxygen therapy is dangerous and is likely to result in serious injury or death of the patient and others from fire.
- There is a risk of fire associated with oxygen equipment and therapy. Do not use near sparks or open flames.
- Use only medical grade oxygen. In the United States, USP applies.
- The Conserver is equipped with a relief valve. If you hear a loud hissing or popping sound coming from the Conserver, discontinue use, close cylinder valve, and contact your Equipment Provider.
- The Conserver is designed to operate with a single lumen, adult cannula with a maximum length of 7 feet (2.1 m) and a maximum flow of ≥ 6 l/min.
- To avoid risk of cross contamination, do not reuse the nasal cannula. The cannula is intended for single patient use only.
- No modification of this equipment is allowed.
- Do not modify this equipment without authorization of the manufacturer.
- If this equipment is modified, appropriate inspection and testing must be conducted to ensure continued safe use of equipment.

WARNING

- **DO NOT USE** without a seal. For optimum safety, use only an OxyGo Inlet Seal. The Inlet Seal supplied with the ConservOx is reusable. **DO NOT USE** any other type of seal.
- To ensure receiving the therapeutic amount of oxygen delivery according to your medical condition the ConservOx ConservOx must;
 - be used only after one or more settings have been individually determined or prescribed for you at your specific activity levels
 - be used with the specific combination of parts and accessories that are in line with the specification of the oxygen conserver manufacturer and that were used while your settings were determined.
- The pulse settings of the ConservOx ConservOx might not correspond with continuous flow oxygen.
- The settings of other models or brands of oxygen therapy equipment do not correspond with the settings of the ConservOx ConservOx.
- Use only water based lotions or salves that are oxygen compatible during setup or use during oxygen therapy. Never use petroleum or oil-based lotions or salves to avoid the risk of fire and burns. Wash and dry hands properly prior to use.
- Do not lubricate replaceable fittings, connections, tubing, or other accessories of the oxygen conserver to avoid the risk of fire and burns.
- Use only spare parts recommended by the manufacturer to ensure proper function and to avoid the risk of fire and burns.
- Wind or strong draughts can adversely affect accurate delivery of oxygen therapy. Using this equipment beside an open window or in front of a fan can affect the accuracy of delivery of oxygen.
Using this equipment in the back seat of an open convertible car can affect the accuracy of delivery of oxygen.
- Use of this device at an altitude above 10,000 ft (3048 m) or outside a temperature of 35°F to 105°F (1.7°C to 40.6°C) is expected to adversely affect the quality of the therapy.
- Oxygen makes it easier for a fire to start and spread. Do not leave the nasal cannula on bed coverings or chair cushions, if the oxygen conserver is turned on, but not in use; the oxygen will make the materials flammable. Turn the oxygen conserver off when not in use.
- If you feel discomfort or are experiencing a medical emergency, seek medical assistance immediately to avoid harm.
- Geriatric, pediatric or any other patient unable to communicate discomfort can require additional monitoring to avoid harm."
- Smoking during oxygen therapy is dangerous and is likely to result in facial burns or death. Do not allow smoking or open flames within the same room of the oxygen conserver or any oxygen carrying accessories. If you smoke, you must always turn the oxygen conserver off, remove the cannula and leave the room where either the cannula or the oxygen conserver is located. If unable to leave the room, you must wait 10 minutes after the flow of oxygen has been stopped.

CAUTION

- Only personnel instructed and trained in its use should operate the Conserver.
- The Conserver contains magnetic, ferrous material that may affect the results of an MRI.
- **DO NOT** autoclave.
- **DO NOT** gas sterilize with Ethylene Oxide.
- **DO NOT** clean with aromatic hydrocarbons.
- Store the Conserver in a clean area when not in use.
- Avoid dropping the Conserver or placing it in a position where it could fall and become damaged.
- Some respiratory efforts of the patient might not trigger the ConservOx Conserver. (Shallow breathers may not be able to trigger the Conserver.) **DO NOT USE** while sleeping.
- Oxygen delivery settings have to be determined for each patient individually with the configuration of the equipment to be used, including accessories.

PRINCIPLES OF OPERATION

The Oxygen Conserver is designed to be used with high-pressure oxygen systems. It consists of a cylinder connection, cylinder contents gauge (if equipped), high-to-low pressure regulator, orifice plate and a conserving demand module. The regulator reduces the high pressure of the cylinder to the working pressure of the orifice plate. The orifice plate uses calibrated orifices to deliver a selected flow to the conserving demand module. The conserving demand module controls the pulse size and timing to the patient. It supplies a pulse of oxygen at the beginning of each breath. This reduces the oxygen demand on the system and limits the drying of the airways. The flow is determined by setting the flow control knob to the prescribed flow. The oxygen is supplied to the patient through the cannula.

SPECIFICATIONS

Inlet Pressure Range: 300 - 3000 psi (2068 - 20684 kPa)

Pressure Gauge Accuracy: 3 - 2 - 3% of full scale

Dimensions: (Are approximate and may vary by model)

Model: 1210-0400

Weight: 9.9 oz (279 g)

Overall Length: 4.75 in (12.07 cm)

Width: 2.63 in (6.67 cm)

Height: 2.50 in (6.35 cm)

Pulse Settings: 1, 2, 3, 4, & 5 l/min Equivalents

Flow Settings: 2 l/min Continuous (1210-0400)

Accuracy: Continuous Settings: within $\pm 10\%$

PULSE ONLY	Accuracy:	Pulse Settings: Within +/- 15% of the nominal bolus value (at each breath rate)
	Savings Ratio:	Up to 5.7:1
	Trigger Method:	Inspiratory effort (Negative pressure from patient inhalation)
	Breathing Frequency:	Up to 35 b/min

Cannula Requirement: Maximum 7 foot (2.1 m) long standard adult single lumen nasal cannula.

Operating Conditions:

Temperature: 35°F to 105°F (1.7°C to 40.6°C)

Altitude: Sea level to 10,000 ft (0 to 3,048 m)

Storage Conditions:

Temperature: -40°F to 140°F (-40°C to 60°C)

Maximum Humidity: 95% Noncondensing

Specifications are subject to change without prior notice. Manuals available on our website: www.applied-inc.com

Specifications for the flowrates and volume for the gas delivered to the patient are expressed in STPD (standard temperature and pressure dry) conditions. (14.69 psi (101.3 kPa) at an operating temperature of 68 °F (20 °C)), dry

Specification tolerances include the uncertainty of the measurement used to determine the specification.

COMPONENT DESCRIPTION

⚠ CAUTION

Missing or illegible labels must be replaced, contact OxyGo

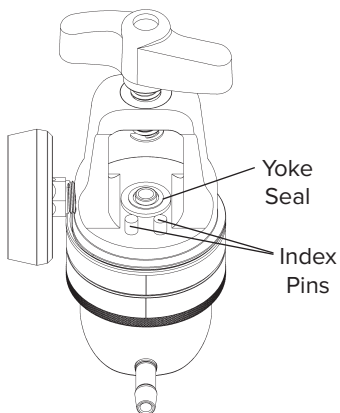
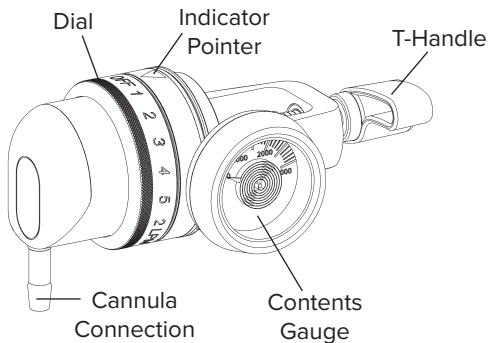

INSTALLATION

WARNING

- Read this User Manual before installing or operating the Oxygen Conserving Regulator.
- Inspect the Conserver and cylinder valve to ensure they are free of oils, greases or other contaminants.
- **DO NOT** direct flow of oxygen at any person, or flammable material when cracking open the cylinder.
- **DO NOT** use without yoke seal.
- **DO NOT** use plastic yoke seals.
- Use an OxyGo yoke seal made of viton and brass.
- The yoke seal supplied with the Conserver is reusable.

CAUTION

- Inspect the Oxygen Conserving Regulator for visual damage before use, **DO NOT USE** if damaged.
- **DO NOT** use tools to tighten T-handle, this can lead to over tightening and will cause damage to the Conserver.
- Be sure all connections are tight and leak free.
- **DO NOT** use liquid leak detector to test for leaks.

Note: For Operational Instructions on how to operate the cylinder consult with your Equipment Provider.

1. Position the cylinder so the oxygen cylinder valve outlet is pointing away from the user and any other person(s).
2. Before installing the Conserver, “crack” cylinder valve by opening the valve slightly to remove any foreign particles and then close valve.
3. Be sure the Conserver is in the “OFF” position. Align “OFF” with the indicating pointer ▽.
4. Be sure the CGA 870 connection high pressure inlet has a yoke seal.
5. Align Index Pins with Index Pin Alignment Holes in Post Valve.
6. Hand tighten T-handle until snug.

OPERATING INSTRUCTIONS

1. Attach a standard adult single lumen oxygen nasal cannula, no longer than 7 feet (2.1 m) to the Conserver's outlet according to the cannula manufacturer's instructions.

⚠ CAUTION

- Use of incompatible accessories can result in degraded performance.
- **DO NOT** block the cannula connection or kink cannula tubing when the Conserver is in use, this may damage the Conserver.
- The proper placement and positioning of the nasal cannula in the nose is critical to the consistent operation of this equipment.

2. Place the cannula over your ears and position the prongs in your nose as instructed by your Provider or cannula manufacturer.
3. Slowly open cylinder valve counterclockwise, until completely open.
4. Turn dial on the Conserver until indicating pointer **∇** is aligned with the prescribed setting.

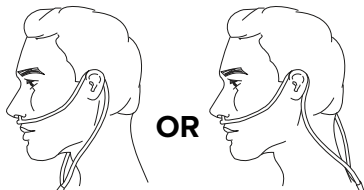

5. Breathe through your nose.

- NOTE:**
- When on a pulse setting, there is flow or a pulse only at the beginning of each breath. If you do not feel the pulse at the beginning of each breath, check the setting. If there is still no pulse, turn dial to an equivalent "Continuous" setting.
 - Because each patient's breathing pattern is different and the environment varies, it may be difficult to feel some low setting pulses.

6. To remove the Conserver from cylinder:
- **Completely close oxygen cylinder valve.**
 - Turn the Conserver dial to any “Continuous” position.
 - Wait for oxygen to stop flowing from Conserver.
 - Remove the Conserver from cylinder valve.
 - **DO NOT** try to loosen T-handle beyond stop. Damage to the Conserver will occur.

 **DANGER**

NEVER attempt to remove the Conserver from a cylinder unless the cylinder valve is closed.

 **WARNING**

- When pointer on contents gauge enters red zone, (500 psi (3447 kPa) and below), it is recommended to change to a full oxygen cylinder.
- **NO OXYGEN** is delivered in between settings.



 **WARNING**



- **DO NOT** place the unit under clothing while in use. When the Conserver is in use, a small amount of oxygen is vented. Wearing the unit under clothing may saturate fabrics with oxygen and cause them to burn rapidly, if exposed to sparks or flame. It may take several hours for oxygen levels in fabrics to return to normal.
- **ALWAYS** insert cylinder and Conserver into bag, cylinder first with gauge facing mesh.

MAINTENANCE / CLEANING

1. Disconnect all connections before cleaning.
2. Clean exterior surfaces of the Conserver with a cloth dampened with mild detergent and water.
3. Wipe dry with a clean cloth.
4. Store the Conserver in a clean area free of grease, oil, and other sources of contamination.

CAUTION

- **DO NOT** use cleaning solutions.
- **DO NOT** immerse the Conserver in any kind of liquid.
- **DO NOT** attempt to repair the *ConservOx* Oxygen Conserving Regulator.
- All repairs must be performed by OxyGo or Authorized Representative.

RETURNS

Returned products require a Returned Goods Authorization (RGA) number, contact OxyGo. All returns must be packaged in sealed containers to prevent damage. OxyGo will not be responsible for goods damaged in transit. Refer to OxyGo Return Policy available on the Internet, www.applied-inc.com.

DISPOSAL INSTRUCTIONS

This device and its packaging contain no hazardous materials. No special precautions need to be taken when disposing the device and/or its packaging.

Please Recycle

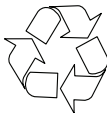

TROUBLESHOOTING

If the Conserver fails to function, consult the Troubleshooting Guide below. If problem cannot be solved, consult your Provider.

TROUBLESHOOTING GUIDE

Problem	Probable Cause	Remedy
No flow	<ol style="list-style-type: none">1. Cylinder valve closed2. Conserver in "OFF" position3. Cylinder empty4. Dial not set at proper position5. Conserver not sensing breath	<ol style="list-style-type: none">1. Open the valve on cylinder2. Set to prescribed setting3. Replace cylinder4. Set dial so indicator points to a setting5. Check position of cannula in nose, DO NOT breathe through mouth
Leaking at cylinder connection	<ol style="list-style-type: none">1. Missing or defective yoke seal2. Defective cylinder valve	<ol style="list-style-type: none">1. Replace with OxyGo yoke seal2. Contact your Provider

LIMITED WARRANTY AND LIMITATION OF LIABILITY

Precision Medical, Inc. warrants that the ConservOx Oxygen Conserving Regulator (the Product) will be free of defects in workmanship and/or material for the following periods:

Two (2) years from date of shipment.

Should any failure to conform to this warranty appear within the applicable period, Precision Medical, Inc. shall, upon written notification thereof and substantiation that the goods have been stored, installed, maintained and operated in accordance with Precision Medical, Inc.'s instructions and standard industry practice, and that no modifications, substitutions, or alterations have been made to the goods, correct such defect by suitable repair or replacement at its own expense.

ORAL STATEMENTS DO NOT CONSTITUTE WARRANTIES.

The representative of Precision Medical, Inc. or any retailers are not authorized to make oral warranties about the merchandise described in this contract, and any such statements shall not be relied upon and are not part of the contract for sale. Thus, this writing is a final, complete and exclusive statement of the terms of that contract.

THIS WARRANTY IS EXCLUSIVE AND IS IN LIEU OF ANY WARRANTY OF MERCHANTABILITY, FITNESS FOR A PARTICULAR PURPOSE OR OTHER WARRANTY OF QUALITY, WHETHER EXPRESS OR IMPLIED.

Precision Medical, Inc. shall not under any circumstances be liable for special, incidental or consequential damages including but not limited to lost profits, lost sales, or injury to person or property. Correction of non-conformities as provided above shall constitute fulfillment of all liabilities of Precision Medical, Inc. whether based on contract, negligence, strict tort or otherwise. Precision Medical, Inc. reserves the right to discontinue manufacture of any product or change product materials, designs, or specifications without notice.

Precision Medical, Inc. reserves the right to correct clerical or typographical errors without penalty.

Manufactured for OxyGo by:



 300 Held Drive
Northampton PA 18067, USA

www.precisionmedical.com

T: (+001) 610-262-6090 • F: (+001) 610-262-6080

ISO 13485 Certified



www.applied-inc.com
888-327-7301